

FABRIC EXPANSION JOINTS.

Tube- and flange expansion joints.

DESCRIPTION

Expansion joints are components used in pipeline, plant, and device construction. They are designed to withstand the same stresses as plant components and pipelines; additionally they must absorb added stresses, movements, or vibrations in axial or lateral direction. The main area of application for fabric expansion joints are plants conveying gaseous media. Precise technical installation data from the user are essential for optimised expansion joint designs to ensure a perfect fit for the relevant usage conditions in industrial plant construction.

PROPERTIES

- Optimised flexibility and highest possible mobility with a low construction height [pipeline gap]
- Resetting/adjustment forces move towards the zero point or are negligibly small in calculations
- A multitude of possible material combinations allows optimised and customised adjustment to prevailing operating conditions
- The manufacturing of large size expansion joints is inexpensive
- Material folding ensures lower transporting costs for large sizes
- Easy installation, can often be carried out by customer's own personnel

APPLICATIONS

Power plants, waste incineration plants, dust removal and filter systems, cement industry, steel industry, drying technology, chemical industry, conveyor technology, fan construction, ventilation technology, marine engineering, etc.

MATERIAL

The multitude of possible material combinations allows the development of optimised solutions, which are generally influenced by prevalent mechanical, chemical, and thermal conditions. The structure of the expansion joint is generally based on the following material groups:

Insulation material

Insulation material - in an appropriate thickness and quality - will prevent thermal as well as mechanical damage to the actual sealing foil. The most frequently used insulation material fabrics are glass fiber, silicate fibers, and ceramic fibers.

Sealing foil

The sealing foil is the actual sealing component of an expansion joint. It is generally sandwiched between two layers of fabric. The most frequently used sealing foils are made of elastomeres, PTFE, or stainless steel.

Carrier fabric

Positioned on the outside of the sealing foil, the carrier foil [generally coated] provides the necessary compression strength and dimensional stability. The most frequently used carrier fabrics are made from polyester, aramid, glass fiber, or silicate fibers.

Coating

The carrier fabric is protected by a coating of various elastomeres, which additionally supports the shape of the expansion joint, and serves as the actual sealing element in simpler construction elements. The most frequently used coatings include neoprene, EPDM, hypalon, silicon, viton, and PTFE.

MOVEMENT SURVEY

The movement survey capacity of the expansion joint depends primarily on the model type of the centre part [AR]; the following are the most common structures:

CENTRE PART	AXIAL ~	LATERAL ~
Straight	- 0.25 x AR	- 0.1 x AR
Concave	- 0.3 x AR	- 0.15 x AR
Pleated	- 0.25 x AR	- 0.3 x AR

MODELS

Tube expansion joint | Attached to te pipe

Suitable for round or oval cross-sections. Mounting strips must be used for rectangular cross-sections, and the duct walls must be drilled. For a vacuum system it is important to note that the expansion joint bellows will pull inward and constrict the flow diameter.

In these cases, support rings must be installed. Max. operating temperatures must not exceed 350 °C, as the fixing point will take on the temperature of the medium. The attachment of the joint is implemented using multi-part hose clamps for sizes between \varnothing 700 mm and 800 mm.

For larger diameters, flange connections are recommended due to their higher sealing capacity.

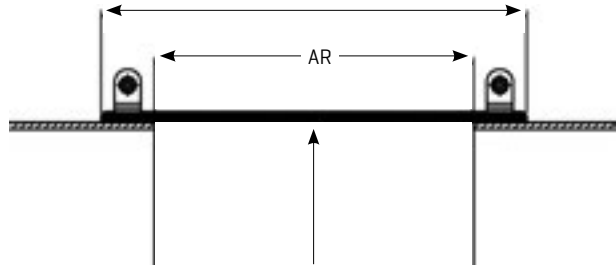

Tube expansion joint | Attached to extracted mounting flange

This installation model covers all cross-section shapes and sizes. Rectangular connection points will require adequate hose diameters, and a drilling of the duct is not required. Due to the good temperature reduction properties in the attachment area, an implementation without pre-insulation will be suitable for temperatures between 400 and 500 °C, and with pre-insulation for temperatures between 600 and 700 °C. With relevant structural measures in place, i.e. inner brickwork lining, temperatures up to 1000 °C will be manageable.

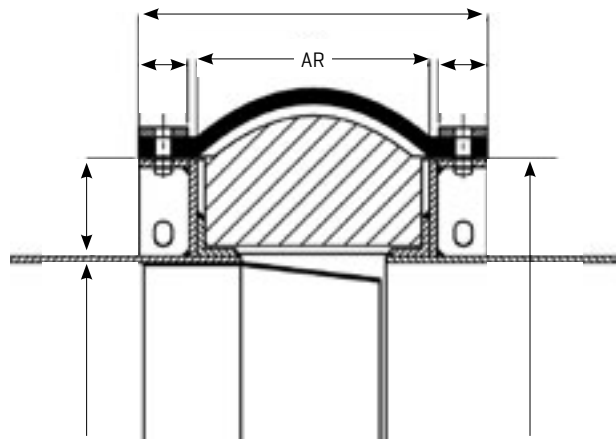

Flange expansion joint

Suitable for use for large dimensions or pre-existing pipeline flanges, higher pressures, and high technical tightness requirements. Due to the inferior heat radiation in the attachment area, operating temperatures should not surpass 450 to 500 °C. With the use of larger flanges, the expansion joint can be placed further outward [away from the flow of the medium], and additionally protected by another insulation or retrofitted insulation. This will allow operating temperatures between 600 and 650 °C.

